

SF6 Gas Insulated Lines (GIL) Application Guide



Introduction

SF6 Gas Insulated Lines (GIL) have many applications beyond new GIS installations. Applications range from power plant substation designs to transmission line connections:

Power Plant Applications

- Design Optimization
- Grid Connections
- Flexible Installation Options

Hydroelectric Power Plants

- Vertical Installations
- Inclined or horizontal tunnels

Transmission Line Applications

- Transmission Line Crossing
- Underground Transmission

Extensions to Existing Substations

- Extensions and Retrofits to GIS Substations
- AIS Substation Applications

Power plant applications

Design Optimization

One of the challenges in the design of a power plant substation is how to maximize its potential while maintaining safe conditions for workers and the surrounding environment. The greatly reduced electric and magnetic fields, combined with the superior dielectric strength of SF6 gas, enable GIL systems to provide a compact power transmission solution. For example, the outside diameter of the 362kV rated GIL design is only 15 inches (381mm) per phase. With a phase spacing of 22 inches (599mm) center to center, a typical 362kV GIL bus circuit requires a trench of only 6 feet (1.85m) in width. This compact right of way requirement is less than 10% of what would be required by conventional transmission lines, yet the GIL system can transmit in excess of 3000MVA.

GIL's compact design is also more adaptable to tight space limitations than typical high voltage cable systems because GIL lines can turn corners at extremely sharp angles, unlike the large radius bends required by cable systems. Also, the large current carrying capacity allows the combination of outputs from multiple generator step-up transformers into feeder circuits, resulting in more compact transmission line and GIS arrangements than would be required with cable.

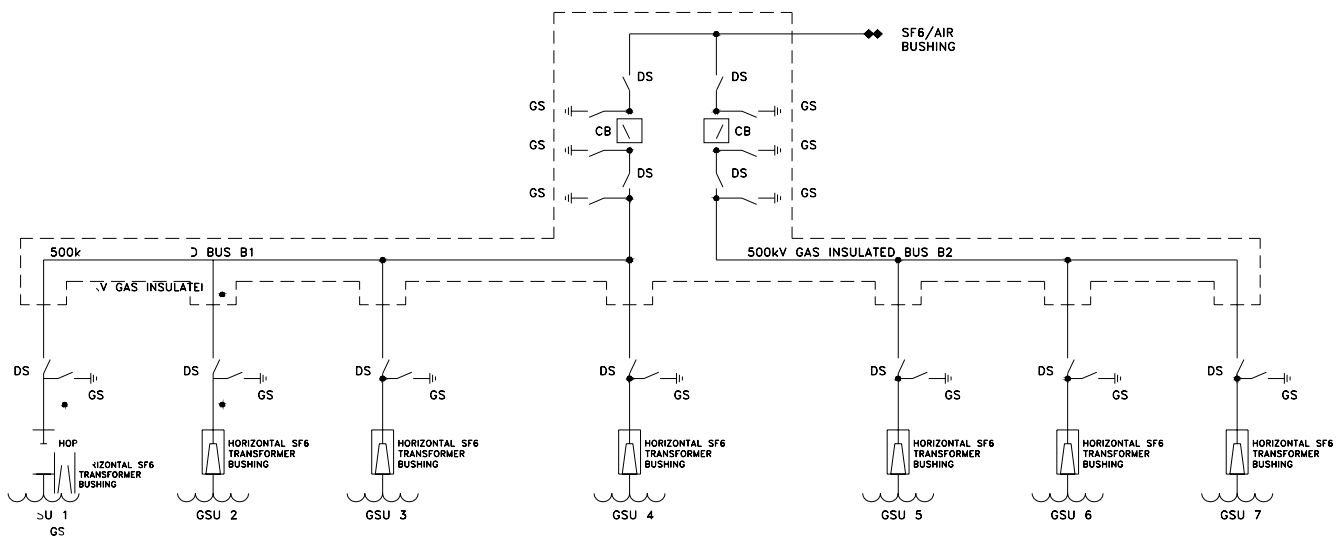

Power plant design optimization

Power Plant 8 in Riyadh, Saudi Arabia was being planned for a 500MW expansion. The original power plant consisted of 380kV GIS and oil filled cables to connect the generator step-up transformers to a 380kV GIS Substation. The initial planned expansion of 500MW consisted of six GE gas turbines and three generator step-up transformers. The issue facing Saudi Electric Company (formerly SCECO) was how to connect the new generator step-up transformers to the GIS substation, 800 meters away. Several obstacles existed that made the expansion difficult:

- Existing 380kV and 138kV oil filled cables installed underground
- Control cable and auxiliary systems underground
- Existing roadways and civil foundations

The space available for installing multiple circuits of 380kV oil cables was limited due to existing buried cable systems and plant equipment. This required that the system be installed above grade. To minimize impact at roadways and other access areas, the system would need to be elevated to allow passage of plant personnel and equipment. In addition, the long range plan for the power plant called for the future addition of two more generating units, requiring additional power transmission capability and ease of installation. GIL proved to be the optimum solution.

The original layout consisted of three independent circuits of 380kV GIL on elevated steel supports, each connecting one generator step-up transformer to the GIS substation 800 meters away. The circuits were installed in a stacked configuration to minimize the right of way requirement. Support structures were installed at spans of up to 18 meters to minimize civil construction requirements. The bus was designed with reserve capacity to allow transmission of the additional power from the future two generating units using the existing system.

Additionally, the bus was designed with reserve capacity to allow for the increase in current that would result from the planned generating capacity expansion. When two new transformers were added later, they required only two new short circuits to connect them to two of the existing GIL circuits. This approach avoided the need for two full additional circuits of approximately 600m each, and also the need to add switching modules to the GIS.



*Power Plant 8, Saudi Arabia
380kV, 1200A GIL System Connecting to Transformers*



*Power Plant 8, Saudi Arabia
380kV, 1200A GIL System Installed Above Ground*



*Bethlehem Power Plant, Pennsylvania, USA
550kV, 2000A Complete Substation From Transformers to Transmission Lines*

Power plant design optimization

Bethlehem Power Plant, Pennsylvania, USA

Conectiv Mid-Merit's planned 1100MW Combined Cycle Power Plant consisted of two power "modules", each rated at 550MW, for connection to a 500kV transmission line. Each power module initially consisted of four generator step-up transformers, three from gas turbines, and one from a steam turbine. The power plant was located on a relatively small space, with an existing 500kV transmission line in close proximity. The design of the power plant had the high side of the generator step-up transformers located near the edge of the property, facing the transmission line. This arrangement did not provide enough space for a conventional substation, or multiple connection circuits to the transformers. An additional challenge was the need to provide an access road between the transformers and the edge of the property. GIL provided a compact and reliable solution for Conectiv.

With no space available for air insulated equipment to connect to the high side of the transformers, and limited space available underground for multiple cable circuits, Avail Bus Systems proposed a single circuit of 500kV bus for each power module. The high current rating of GIL enabled all four generator step-up transformers of each power module to be combined into a single circuit, with GIS disconnect switches located at each transformer for isolation. To provide space for an access road, Avail designed the 500kV bus circuits for installation below grade in a covered trench within the available space. The space above the covered trench was utilized for the access road. To isolate each power module from the transmission grid, Avail supplied 500kV GIS substation breakers from VA TECH located at the edge of the power plant property. Avail provided the entire solution including turnkey installation and commissioning of the 500kV GIL, VA TECH GIS circuit breakers and disconnect switches, SF6 surge arresters from Toshiba, and complete control equipment.



*Baxter Wilson Power Plant, Mississippi, USA
550kV, 3000A Grid Connection Across Transmission Lines*

Power plant applications: grid connections

New power plant projects, and many extensions to existing power plants, require new connections to the transmission grid. In many cases obstacles exist that make conventional transmission line connections unfeasible. Possible obstacles include crossing existing transmission lines, traversing wetlands or hazardous areas, or limited space availability. GIL's compact design combined with flexible installation options can help make these vital connections with reduced permitting and installation time.

Baxter Wilson Power Plant, Mississippi, USA

Entergy was adding additional generating capacity to their existing Baxter Wilson Power Plant outside of Vicksburg, Mississippi, requiring a new connection to the transmission grid. The new generator step-up transformers were located on the opposite side of the power plant from the 500kV transmission grid connection point, with several obstacles in between. Existing transmission lines crossing the power

plant property would have presented a permitting issue for conventional transmission equipment, and an existing flood plain prevented the use of buried cable systems. Avail Bus Systems proposed a solution to Entergy that addressed these issues, and would enable them to get power to the grid in the shortest possible time.

The solution provided to Entergy included a single 550kV rated circuit installed above ground under existing 230kV and 500kV transmission lines. The circuit was installed on concrete foundations elevated above ground where flooding occurred each spring. The height of the circuit was established to prevent the water level from rising to the level of the GIL. Each end of the circuit terminated in SF6-to-air bushings for connection to the generator step-up transformers and to the overhead transmission line. Gas monitoring system alarms were connected into the power plant control system for protection. The total solution was provided to Entergy on a turn-key basis by Avail, including installation and commissioning, nine months after the order was placed. Significantly less time than permitting for a new transmission line.



*Teesside Combined Cycle Power Plant, England
275kV GIL Connections Between Generator Step-up Transformers and GIS Building*

Power plant applications: flexible installation options

Every station layout design has certain physical boundaries to which the transmission components must adhere. When determining a transmission line route through a given area, the choice of available power transmission methods may become limited. If the space available precludes the use of conventional air insulated equipment, or obstructions below grade prevent the use of cable systems, one possible solution is to provide an elevated system.

Teesside Power Plant, Teesside, England

Teesside is a 1725 MW combined-cycle gas-fired power plant located in England. The arrangement of the generators and transformers, and the location of the

gas insulated switchgear created a need for an extensive array of 275kV, 1200 ampere connection circuits from the generator step-up transformers to the gas insulated substation. The amount of space available for the connection circuits was very limited. An installation below grade was not possible due to a relatively high water table, and the existence of underground steam lines to an adjacent chemical plant. Access roads at ground level made a ground level installation unfeasible. The only solution was to elevate the connection circuits above ground in a compact right of way that allowed access of equipment and personnel underneath.

Avail Bus Systems provided the optimum solution with a smaller right of way, increased access, and a lower installed cost than 275kV oil cable.



*Teesside Combined Cycle Power Plant, England
275kV GIL Elevated Connection Circuits*

Power plant applications: flexible installation options

Teesside Power Plant, Teesside, England (Continued)

What made this project unique for Avail Bus Systems was the height requirement. Due to the access requirements, the GIL system was elevated as high as 9 meters (29 feet) above grade. Support structures for this project were designed to hold as many as five circuits (fifteen phases) of GIL, with at least six phases running at the maximum height. The support structures were spaced approximately 14 meters (45 feet) to provide as much accessibility to other equipment as possible.

One important consideration for the system design was thermal expansion of the long runs, in excess of 100 meters at the longest point. The system must accommodate thermal expansion due to increased ambient temperature, solar loading, and self heating due to operation. Normally,

long systems utilize enclosure bellows to accommodate thermal expansion and contraction. For the Teesside project, with an elevation of up to 9 meters, the supporting requirements to withstand the pressure thrust of a standard enclosure bellows would be prohibitively expensive, and would create excessive foundation loads. The solution was to design the system utilizing Avail's flexible elbow design to accommodate the anticipated thermal expansion. This provided an economical solution that only Avail's system design can provide.

As part of the overall system, Avail provided SF6 insulated surge arresters at each generator step-up transformer to protect the transformers from switching surges and high speed transients. Avail also provided SF6 enclosed transformer bushing tanks with isolation links, and metering CT's for each circuit. The Teesside Project, consisting of over 5,400 single phase meters of GIL, was installed and commissioned in 1992.

Hydroelectric power plant applications

Hydroelectric generating stations often require transmission of the energy over large vertical distances or long underground tunnels. Since it is usually more economical to transmit the power at transmission voltages rather than the generation voltage, the step-up transformers are often located at the lowest elevation while the transmission system is most accessible at higher elevations. At transmission voltages, there are four possible methods to transmit this power:

- Air insulated bus
- High pressure fluid filled cable
- Solid dielectric cable
- SF₆ gas insulated bus

The air-insulated bus would require large clearances. Shaft and tunnel sizes would need to be very large to accommodate this solution. In addition, there is a significant safety hazard due to the exposed high voltage conductors. While the oil cable would solve the size problem, it has two distinct disadvantages: (1) large vertical drops result in very large pressure heads, which could lead to premature failure; (2) the risk of catastrophic damage resulting from a fire occurring in the cable system. If a fault were to occur in one cable circuit, the potential fire could spread to the adjoining circuits eliminating all power transmission capabilities. Solid dielectric cable, while not as flammable as oil cable, still offers a potential fire hazard, and has significant long term reliability issues when cable joints are used. In vertical applications, solid dielectric cable is subject to stretching and conductor core slippage. Special measures are required to support the cable over long vertical distances to minimize the potential risk of stretching and failure, particularly at cable joints.



*Balsam Meadows Pumped Storage Plant, California, USA
230kV GIL Exit From Top of Shaft Enclosure Building to Overhead
Line Bushings*

The Utilization of GIL for Vertical Shaft Applications Offers the Following Advantages

- GIL is enclosed and grounded, reducing clearance requirements and shaft sizes. The safety of dead-front construction eliminates any high voltage safety hazards.
- SF₆ is an inert gas, eliminating any potential fire hazard. The pressure head with SF₆ gas is very low, even in long vertical installations.
- The high current carrying capacity of GIL can reduce the total number of circuits required to transmit power from the underground cavern, while also reducing power losses.
- The design of GIL enclosures eliminates the risk of stretching or mechanical damage, with simple supporting methods.
- The GIL system is designed and tested for a reliable operating life of 50 years.



*Balsam Meadows Pumped Storage Plant, California, USA
230kV GIL Bushings Installed in Transformer Room*

Hydroelectric power plant applications

Balsam Meadows Hydro Electric Station

The 242kV, 1200 amp GIL system was installed in a 328m (1072 feet) high shaft with a diameter of 6m (20 feet). In addition to the GIL, the shaft contains an elevator, power and control cables, and functions as a ventilation shaft. For the underground powerhouse. The bus system design includes short horizontal sections at the top and bottom ends of the vertical shaft for connection to the overhead transmission line and generator step-up transformer. Conventional air insulated connections are used in the transformer room to simplify the electrical system design, including air insulated disconnect switches and surge arresters. Gas insulated disconnect switches, ground switches, and surge arresters were not required due to sufficient clearance being available above the transformer.



*Revelstoke Hydroelectric Project, British Columbia, Canada
550kV, 4000A GIL Installed in Inclined Tunnel*

Hydroelectric power plant applications

Revelstoke Hydroelectric Project

Another example of GIL's applications in hydroelectric projects is British Columbia Hydro's Revelstoke Project in Canada. This hydroelectric plant included gas insulated switchgear in the underground powerhouse, and connection circuits installed in an inclined tunnel to a gas insulated substation where the output of the power plant connects to the transmission grid. Avail Bus Systems provided the best solution for the connections between the GIS substations.

Within the Revelstoke powerhouse, there are gas insulated circuit breakers and disconnect switches at each generator step-up transformer, and a dual set of 500kV GIS configurations connecting the generator transformer output into two main feeder circuits. At the substation building end, another set of 500kV GIS modules connects the feeders to the outgoing overhead lines, and a separate

230kV GIS substation receives incoming power for internal plant service. The feeder circuits, including the connections to the 500kV GIS in the powerhouse, utilize dual circuits of 550kV, 4000 A rated GIL bus.

The high current rating of GIL, combined with the switching configuration, enables the full output of the Revelstoke power plant to be transmitted through either one of the two feeder circuits. This provides 100% redundancy for plant operation. This system redundancy could not be accomplished using conventional cable systems. The GIL allowed a compact installation along the walls of the tunnel, and, because of its fully grounded enclosure, it permitted the use of the tunnel as the main access route to the powerhouse.

Another GIL circuit, outside the substation building, connects the incoming 230kV transmission lines to the 230kV GIS substation, from which conventional 230kV oil cable is used to transmit power into the rest of the power plant.

Underground transmission applications

Underground Transmission

There are two kinds of underground GIL installations: buried and open or covered trenches. Buried installations have the advantage of lower installation costs in open fields. Trenches are necessary when crossing roads or installing in areas where water tables are close to ground level. Either way, below-ground installations are more aesthetically pleasing, eliminate above ground congestion, and reduce right-of-way requirements. Avail Bus Systems installed its first buried underground installation at the Hudson Generation Station in New Jersey, USA in 1972, which is still in operation today.

Buried Installation

Buried GIL installations offer the advantage of reduced installation costs by eliminating civil foundations and trench fabrications. Buried installations are particularly applicable in areas where space is limited, or it is preferred to limit access to the system. Applications include buried transmission lines in urban or congested areas, and connection circuits within power plants where space is at a premium. Buried GIL systems cannot transmit as much current as open air systems. The continuous current rating depends greatly on the phase spacing, resistivity of the thermal sand used to backfill the system, and the ambient temperatures of the surrounding soil. As a general guideline, buried GIL systems transmit 40% less power than an equivalent open air GIL systems.

Avail's buried system utilizes an extruded polyethylene coating on the enclosure to prevent corrosion, and does not require a cathodic protection system. Adjacent sections are welded together in the field, and the completed joints are wrapped in polyethylene tape to prevent corrosion.

Open or Covered Trench Installation

Road crossings or power plant and substation access are the main considerations when choosing a trench installation. The Midway Sunset Cogeneration Project is a perfect example of the advantages of trenched transmission. The layout consisted of three 242 kV circuits. Each circuit crossed the path of the plant's main access road. Placing the GIL in trenches allowed for an undisturbed road routing as well as access to the trench's access panels for easy installation and maintenance of the bus between the GIS and connecting transformers. Figure 6 shows a typical combined trenched and above ground installation.

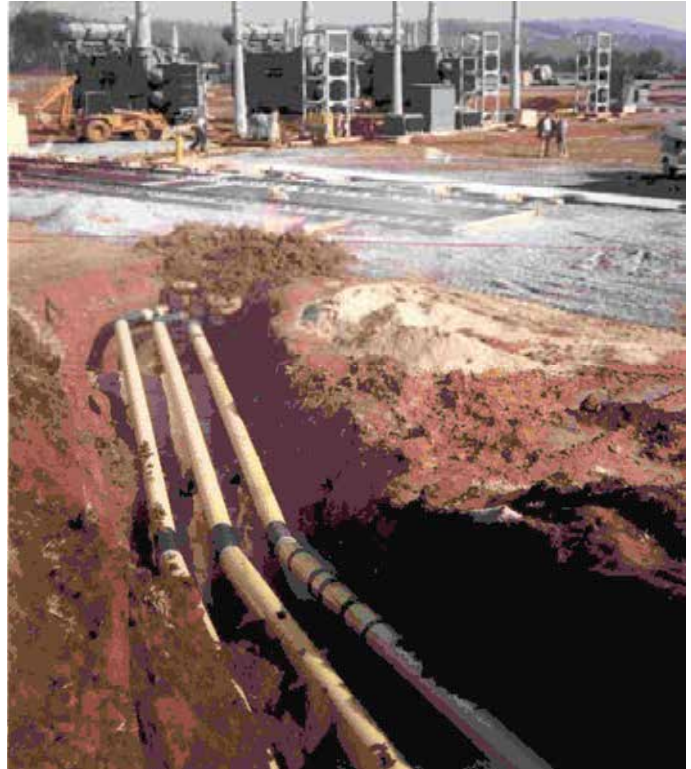

*Spy Run Substation, Indiana, USA
138kV, 1250A Direct Buried GIL System*



*Midway Sunset Cogeneration Plant, California, USA
242kV, 2000A Combined Trench and Above Ground Installation*

Extensions to existing substations

Retrofit of Older GIS Installations

Substations often require new equipment to upgrade existing facilities, or to replace damaged equipment. This can require interfacing to equipment from different manufacturers. If damage occurs to an in-service substation, replacement parts are required immediately to minimize outage time. In the case of a retrofit to an existing GIS substation, the ability to design and install a variety of interfaces, and to allow sufficient installation tolerance is paramount. The existing equipment could include GIS supplied by different manufacturers who may follow different design philosophies and operating parameters. In other retrofit cases, outdated equipment must be replaced. The challenge is to minimize the outage time required to affect the change, and to use as much existing peripheral equipment as possible to reduce costs. Avail Bus Systems offers solutions to the problems faced when retrofitting or extending existing installations including turnkey installation and commissioning.

Consolidated Edison Dunwoodie Station

The original Dunwoodie substation was commissioned in 1974 with ITE GIS equipment. The layout is a 345 kV ring bus arrangement consisting of six dual-pressure ITE circuit breakers and interconnecting ITE bus. The station contains G&W oil cable pothead interfaces and GE capacitive voltage transformers (CVT's). The substation also has three feeder circuits with SF6-to-air bushings to connect to overhead lines. The Dunwoodie substation functioned well until 1988 when Consolidated Edison experienced an oil cable fire which destroyed a circuit breaker, the adjacent oil cable pot heads, interconnecting breaker bus, and disconnects.

In response to Consolidated Edison's emergency requirements, Avail provided interconnecting breaker bus to bypass the damaged breaker position and re-energize the ring. The bus left future expansion capabilities to interface to a new circuit breaker position that would be supplied at a later date. The interconnecting bus required adaptations to existing ITE bus. Avail was the only manufacturer that could respond to this emergency.

In 1990, Mitsubishi Electric provided a replacement GIS circuit breaker, and again Avail provided the necessary interconnecting bus, which this time included interfaces to both ITE and Mitsubishi GIS. At the same time, an additional feeder circuit with SF6-to-air bushings was provided.



*Seabrook Nuclear Power Plant, New Hampshire, USA
345kV, 3000A Combined trench and above ground Installation*

Seabrook Nuclear Power Plant Substation

Another retrofit example is the Seabrook gas insulated substation project. The Seabrook Station 345kV ITE GIS and Bus, had developed a history of unreliability due to leaks and insulator failures within the bus. This was a particular cause of concern within areas of the substation that were not protected by redundant sections of the installation, thereby having no backup in case of section bus failures.

Avail, backed by its established record of reliability and long-term service, was selected to replace the ITE bus for these critical connections. Replacement sections involved connections from the GIS to both main transformers and to auxiliary transformers.

In addition to offering a reliable bus design, Avail was able to complete the installation within a one week outage to comply with the NRC approved outage schedule, and under tight space and access conditions. The first of the Seabrook bus installations has been in service without fault since its completion in 1990.



Claireville Transmission Station, Ontario, Canada
250kV Bus Line Exits

Extensions to existing substations

Long-Term Extensions

Many of the same challenges presented by a retrofit project are also encountered when expanding existing stations. There are various interfaces to be designed, and restrictive outage schedules that must be adhered to. When proposing long term extensions to existing substations, there are several considerations including increased system ratings, control and operating procedures, and physical space limitations. Avail Bus Systems can assist in developing a plan that addresses all of these issues.

Claireville Transmission Station, Ontario, Canada

Often gas-insulated substations only allow unidirectional reductions in yard dimensions due to the space needed for incoming lines. At the Claireville Transmission Station, Hydro One (formerly Ontario Hydro) reduced yard dimensions in all directions with the “spaghetti junction” arrangement of bus circuits. The decision to use GIS switchgear was based on the size of the station and its location near urban centers. A conventional station at Claireville would require approximately two hundred acres of land. The use of GIS and gas insulated bus reduced the space requirement by 80 percent, to approximately forty acres. The Claireville Station was initially commissioned in 1975 and has undergone several phases of expansion.

The station consists of multiple circuits of GIL arranged to untangle dozens of line exit circuits and feed twenty-six 550kV and fifty-two 250kV GIS circuit breakers. The GIS is housed in an elevated switchgear building, and the GIL exits through the floor. Incoming lines enter the station along power corridors from the North, South, East and West. In 1991, Avail, in conjunction with ABB, added the following equipment to increase switching capacity at Claireville:

- One bay of 250kV GIS and three 250kV, 4000A GIL line exit circuits
- One bay of 550kV GIS and three 550kV, 4000A, 1800kV BIL GIL line exit circuits
- Three 550kV, 1800kV BIL CGIT bus circuits connecting to existing Alstom GIS (former GEC Alstom)
- Four circuits of 250kV 4000A CGIT bus interfacing to existing 230kV 3000A Avail bus

Over 4000 meters of Avail bus were supplied to the Claireville station. Extensive use of CAD was required to insure that the new system would not interfere with access platforms, civil foundations and existing equipment above and below grade. Additional design parameters considered installation requirements, including; clearance for welded installation of the bus sections, personnel access, and installation sequencing to accommodate outage schedules.



availinfra.com/bus-services

51 Alder St.
Medway, MA, 02053
508.533.0385